



3-Phase DD Motor Driver

Overview

The LB1620 is a 3-phase DD motor driver IC especially suited for use in VCR capstan motor drive, drum motor drive, and floppy disk motor drive applications.

Functions and Features

- 3-phase motor driver.
- Capable of controlling drive current.
- On-chip 3-phase control signal generator.
- Phase/speed control pin.
- Forward/reverse rotation control pin.
- Applicable to β /VHS, NTSC/PAL/SECAM.

Package Dimensions

unit: mm

3037A-DIP20H

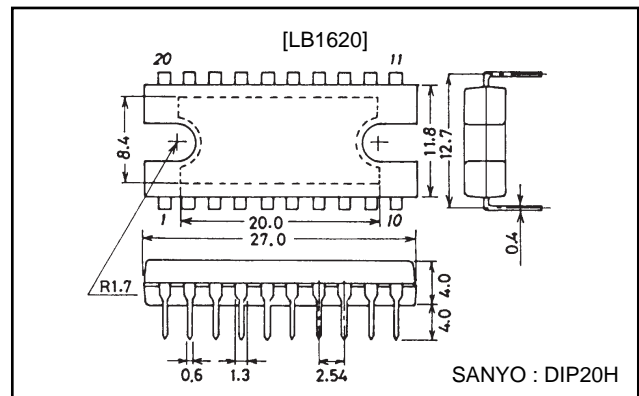

Specifications

Maximum Ratings at $T_a=25^\circ\text{C}$

Parameter	Symbol	Conditions	Ratings	Unit
Maximum supply voltage	V_{CC1}		28	V
	V_{CC2}		14	V
Maximum load current	I_L		1.5	A
Allowable power dissipation	Pd max	Ideal heat dissipation	15	W
		Without heat sink	3	W
Operating temperature	T_{opr}		-20 to +75	$^\circ\text{C}$
Storage temperature	T_{stg}		-55 to +150	$^\circ\text{C}$

Allowable Operating Condition at $T_a=25^\circ\text{C}$

Parameter	Symbol	Conditions	Ratings	Unit
Supply voltage	V_{CC1}		8.5 to 26.4	V
	V_{CC2}		8.5 to 14.0	V

Pin Assignment

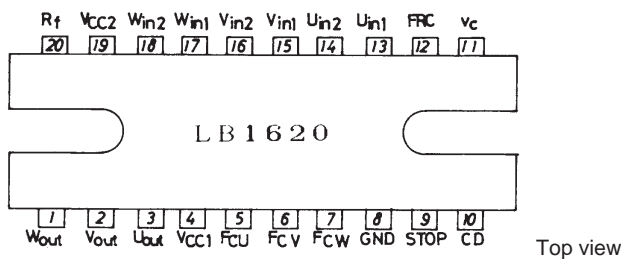

LB1620

Electrical Characteristics at $T_a=25^\circ\text{C}$, $V_{CC1}=12\text{V}$, $V_{CC2}=9\text{V}$

Parameter	Symbol	Conditions	Ratings			Unit
			min	typ	max	
Current drain	$I_{CC\ off}$	$V_c=0\text{V}$, $V_{stop}=2\text{V}$, $I_{CC1}+I_{CC2}$		12	18	mA
	$I_{CC\ dri}$	$V_c=7\text{V}$, $V_{stop}=2\text{V}$, $I_{CC1}+I_{CC2}$		22	40	mA
Saturation voltage	$V_{O(sat)1}$	$I_O=0.58\text{A}$, $V_{CC1}=9.6\text{V}$, $V_{O(sink)}+V_{O(source)}$			2.1	V
	$V_{O(sat)2}$	$I_O=1\text{A}$, $V_{CC1}=18\text{V}$, $V_{O(sink)}+V_{O(source)}$			5.0	V
In-phase voltage range			2.0		$V_{CC2}-2.5$	V
Motor forward rotation input voltage range			2.0		V_{CC2}	V
Motor reverse rotation input voltage range			0		0.3	V
Interphase current variation		Driver stage	-25	0	+25	%
		Output stage	-25	0	+25	%
Speed control voltage (off)	V_{c1}	$R_f=0\Omega$, $R_s=0\Omega$, FC pin→GND current=5 μA			4.0	V
Speed control voltage (on)	V_{c2}	$R_f=0\Omega$, $R_s=0\Omega$, FC pin→GND current=0.5mA	4.5			V
	V_{c3}	$R_f=1\Omega$, $R_s=100\Omega$, $V_{Rf}=100\text{mV}$		4.6		V
Closed loop voltage gain		$R_f=1\Omega$, $R_s=100\Omega$, $I_L=100\text{mA}$		0.44		A/V
Input sensitivity				20		mV

LB1620 Truth Table

	Source Sink	Input			Forward/Reverse Control (FRC)
		U	V	W	
1	W phase → V phase	H	H	L	L
	V phase → W phase	H	H	L	H
2	W phase → U phase	H	L	L	L
	U phase → W phase	H	L	L	H
3	V phase → W phase	L	L	H	L
	W phase → V phase	L	L	H	H
4	U phase → V phase	L	H	L	L
	V phase → U phase	L	H	L	H
5	V phase → U phase	H	L	H	L
	U phase → V phase	H	L	H	H
6	U phase → W phase	L	H	H	L
	W phase → U phase	L	H	H	H

Input : "H" : Each phase input (1) is more than 0.2V higher than each phase input (2).

"L" : Each phase input (1) is more than 0.2V lower than each phase input (2).

Forward/reverse control : "H" : 2.0 to V_{CC2}

: "L" : 0 to 0.3V

LB1620

Equivalent Circuit Block Diagram and Peripheral Circuit

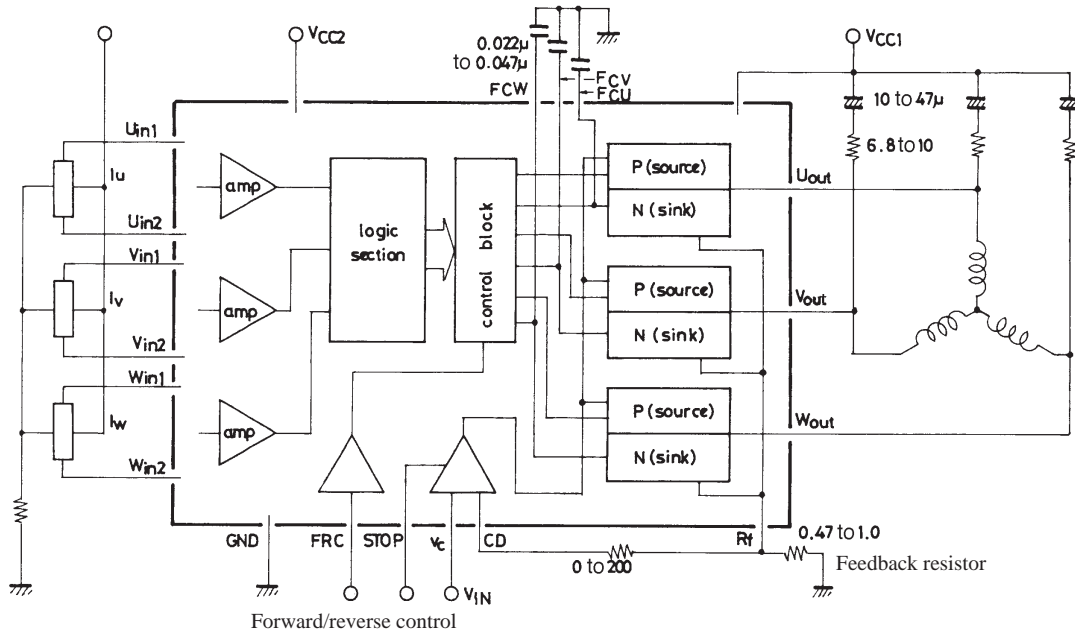

Unit (resistance : Ω, capacitance : F)

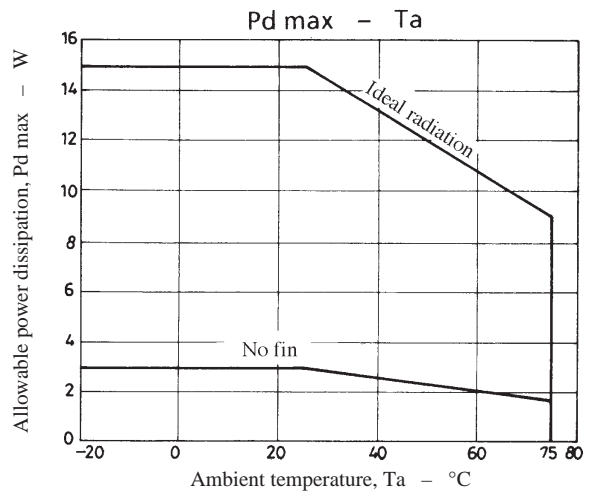
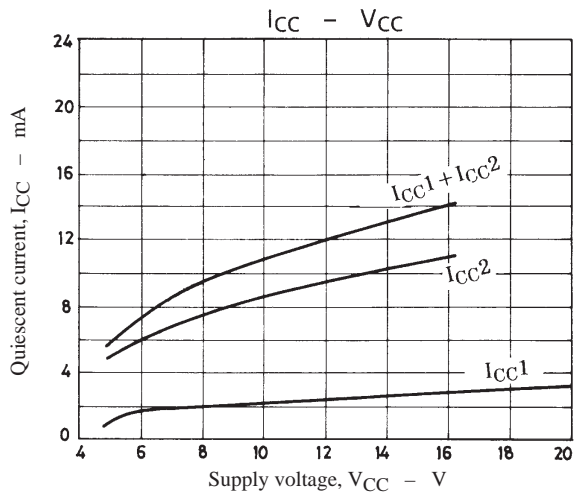
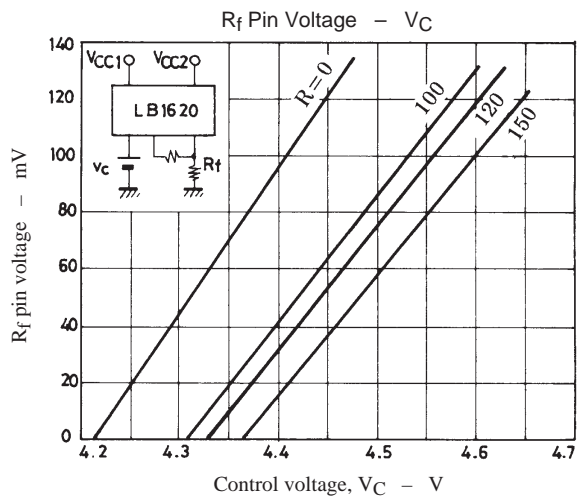
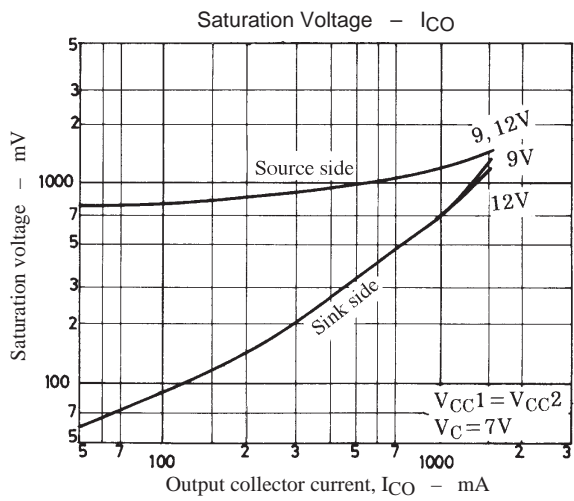

LB1620

Pin Description

Pin name	Pin No.	Function
U _{IN1} , U _{IN2}	13, 14	U phase Hall element input pin, "H" of logic : $V_{IN1} > V_{IN2}$
V _{IN1} , V _{IN2}	15, 16	V phase Hall element input pin, "H" of logic : $V_{IN1} > V_{IN2}$
W _{IN1} , W _{IN2}	17, 18	W phase Hall element input pin, "H" of logic : $V_{IN1} > V_{IN2}$
U _{OUT}	3	U phase output pin
V _{OUT}	2	V phase output pin
W _{OUT}	1	W phase output pin
V _{CC1}	4	Power supply pin for applying output
V _{CC2}	19	Power supply pin for applying voltage to each section other than output section. The control point of control voltage is at approximately 1/2 of this voltage. This voltage must be stabilized to be free from ripple, noise, etc.
R _f	20	Output current detect pin. By connecting R _f across this pin and GND pin, output current is detected as voltage.
C _D	10	Pin for fetching current (voltage) detected with R _f . By connecting a resistor across C _D pin and R _f , speed control start voltage can be fine-adjusted.
STOP	9	Overcurrent protection pin. Voltage being lower than that on C _D pin is taken to be identical to overcurrent flow, causing output to be cut off. Off-state is held. For example, if STOP pin is set to 1.5V for R _f =1Ω, approximately 1.5A or more flows at output, causing output to be cut off.
F _{CU}	5	Frequency characteristic compensation pin.
F _{CV}	6	Closed loop oscillation in current-controlled system (including motor, F/V converter) is stopped.
F _{CW}	7	
V _C	11	Speed/phase control pin. Control starts at approximately 1/2 of V _{CC2} . Control is of current-controlled type that controls output current. For R _f =1Ω, LB1620 closed loop has gm of 0.44A/V typ, which can be adjusted by varying R _f .
GND	8	GND for other than output. Minimun potential of output transistor is at R _f pin.
F/R _C	12	Forward/reverse rotation control pin. By setting this pin to "H" (more than 2V) / "L" (less than 0.3V), truth value is changed to perform forward/reverse rotation.

Sample Application Circuit

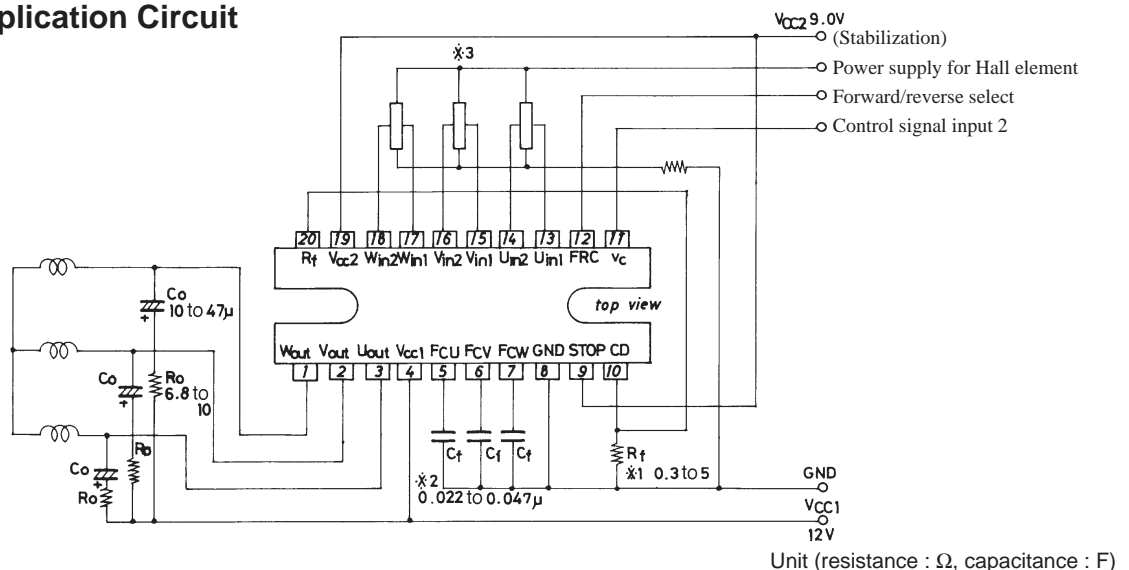

Notes on Sample Application Circuit

- *1. R_f is determined by starting torque required for coil impedance F/V conversion voltage (control input). R_f should be 0.3Ω to 5Ω .
- *2. C_f is for stopping oscillation and is determined by motor characteristic and F/V converter-included closed loop characteristic. C_f should be $0.022\mu F$ to $0.047\mu F$.
- *3. For how to connect Hall element, either parallel connection or series connection is available as long as input voltage is within the range specified.

Timing Chart

Forward/reverse control "L" pin 12

Forward/reverse control "H" pin 12

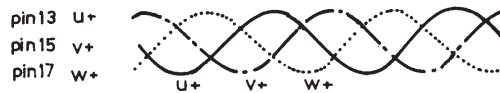
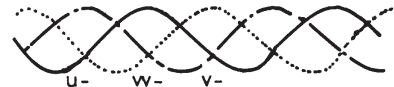

u	L	L	L	H	H	H	L	L	L	H	H	H
v	H	H	L	L	L	H	H	H	L	L	L	H
w	L	H	H	L	L	L	H	H	H	L	L	L

From truth table

u	H	H	H	L	L	L	H	H	H	L	L	L
v	H	L	L	L	H	H	H	L	L	L	H	H
w	L	L	H	H	H	L	L	L	H	H	H	L

From truth table

U	H	H	M	L	L	M	H	H	M	L	L	M
V	L	M	H	H	M	L	L	M	H	H	L	L
W	M	L	L	M	H	H	M	L	L	M	H	H

u	M	H	H	M	L	L	M	H	H	M	L	L
v	H	M	L	L	M	H	H	M	L	L	M	H
w	L	L	M	H	H	M	L	L	M	H	H	M

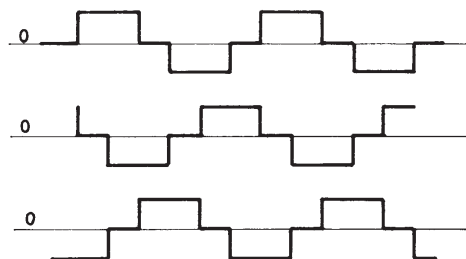
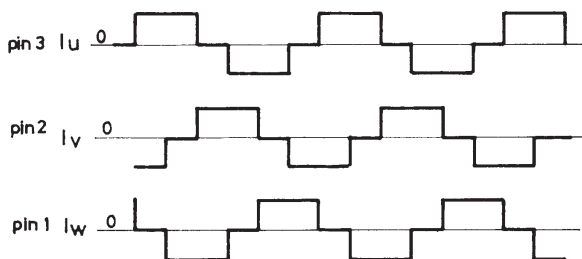
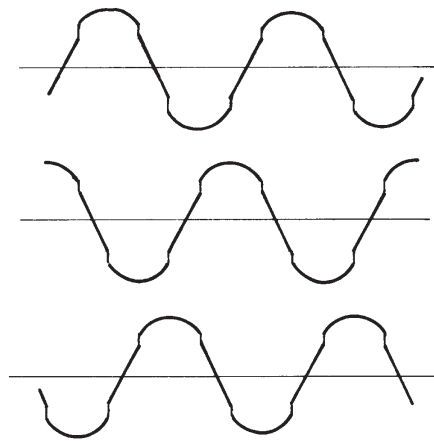
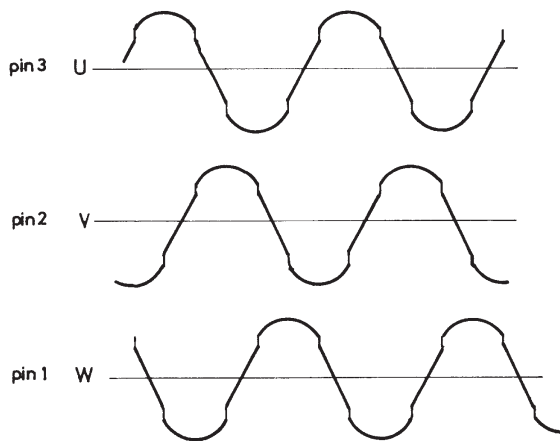

- No products described or contained herein are intended for use in surgical implants, life-support systems, aerospace equipment, nuclear power control systems, vehicles, disaster/crime-prevention equipment and the like, the failure of which may directly or indirectly cause injury, death or property loss.
- Anyone purchasing any products described or contained herein for an above-mentioned use shall:
 - ① Accept full responsibility and indemnify and defend SANYO ELECTRIC CO., LTD., its affiliates, subsidiaries and distributors and all their officers and employees, jointly and severally, against any and all claims and litigation and all damages, cost and expenses associated with such use:
 - ② Not impose any responsibility for any fault or negligence which may be cited in any such claim or litigation on SANYO ELECTRIC CO., LTD., its affiliates, subsidiaries and distributors or any of their officers and employees jointly or severally.
- Information (including circuit diagrams and circuit parameters) herein is for example only; it is not guaranteed for volume production. SANYO believes information herein is accurate and reliable, but no guarantees are made or implied regarding its use or any infringements of intellectual property rights or other rights of third parties.

This catalog provides information as of October, 1997. Specifications and information herein are subject to change without notice.